

(No Model.)

3 Sheets—Sheet 1.

H. BITNER.  
ELECTRIC LOCOMOTIVE.

No. 600,134.

Patented Mar. 8, 1898.

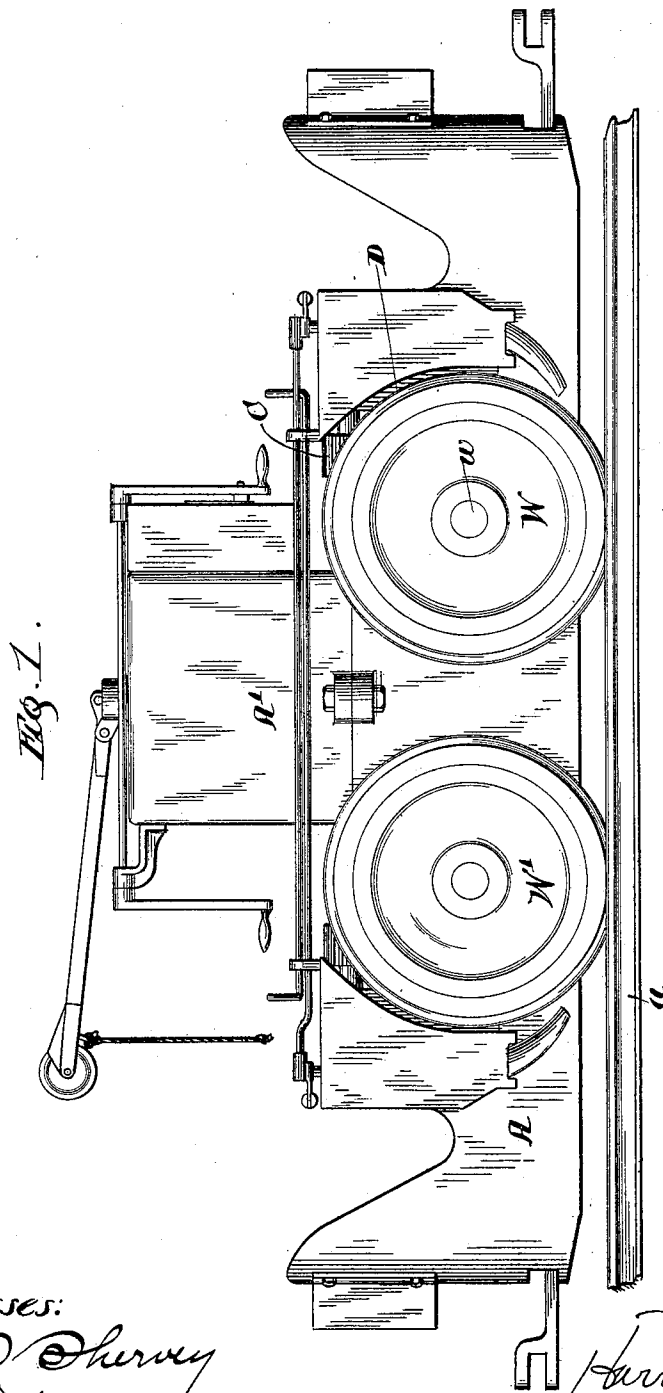

Witnesses:  
Chas. O. Sherry  
M. L. Jackson

Inventor:  
Harry Bitner.

H. BITNER,  
ELECTRIC LOCOMOTIVE.

No. 600,134.

Patented Mar. 8, 1898.

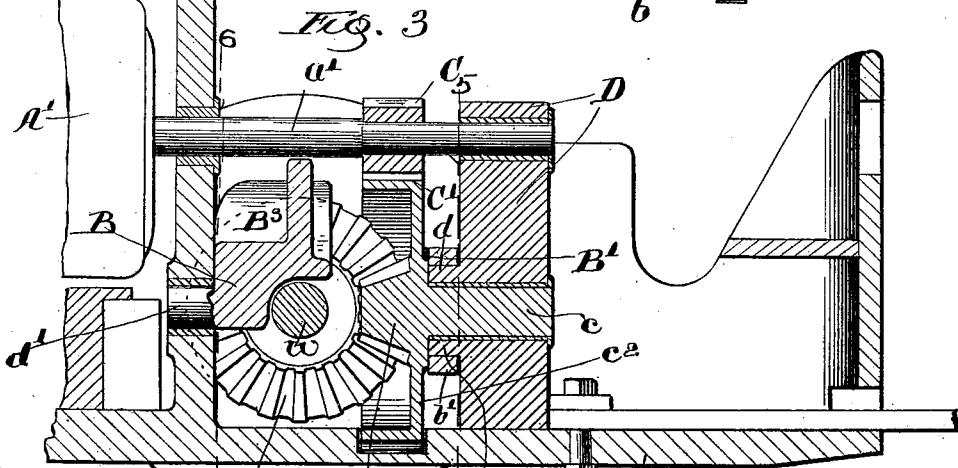
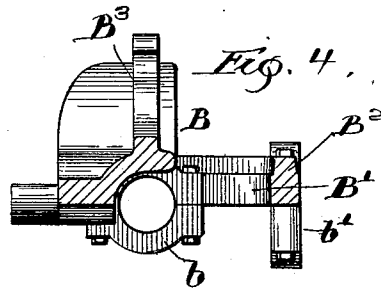
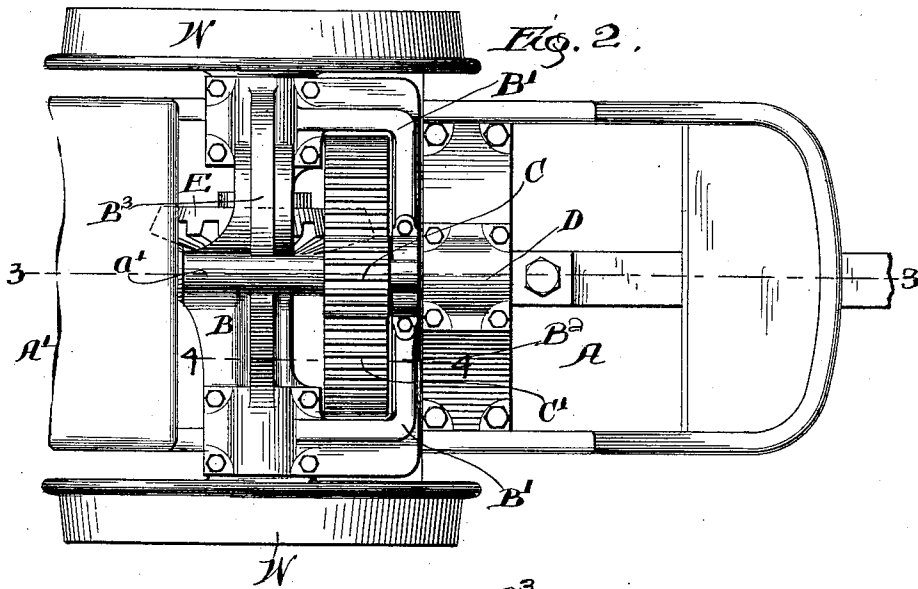

Witnesses: *Chas. C. Durvey*  
*M. L. Sheahan*

Inventor:  
*Harry Bitner*

(No Model.)

3 Sheets—Sheet 3.

H. BITNER.  
ELECTRIC LOCOMOTIVE.

No. 600,134.

Patented Mar. 8, 1898.

FIG. 5.

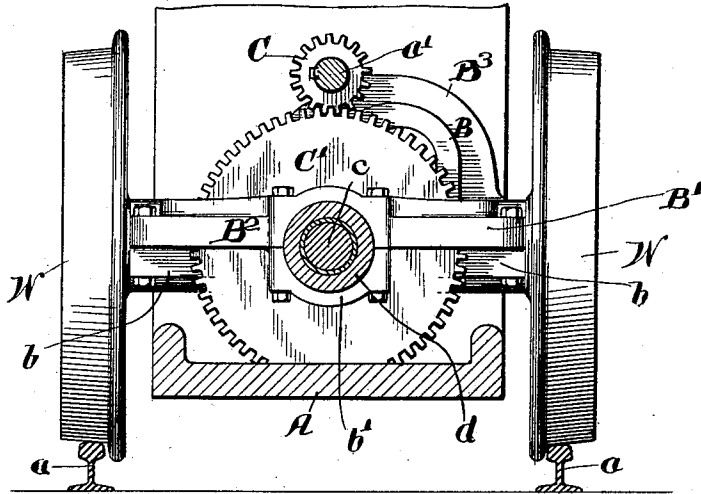
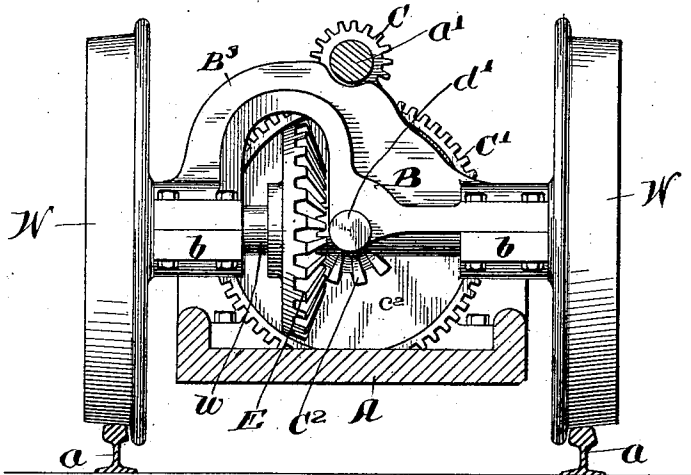

FIG. 6.



Witnesses:

Chas. O. Sherway.  
M. L. Jackson

Inventor:

Harry Bitner.

# UNITED STATES PATENT OFFICE.

HARRY BITNER, OF CHICAGO, ILLINOIS.

## ELECTRIC LOCOMOTIVE.

SPECIFICATION forming part of Letters Patent No. 600,134, dated March 8, 1898.

Application filed June 19, 1896. Serial No. 596,156. (No model.)

*To all whom it may concern:*

Be it known that I, HARRY BITNER, a citizen of the United States of America, residing at Chicago, in the county of Cook and State of Illinois, have invented certain new and useful Improvements in Electric Locomotives, of which the following is a specification.

My invention relates to certain improvements in electric locomotives, and more particularly to that class of locomotives which are used in mines, excavations, and the like. The rails upon which these locomotives run are generally laid without great care, so that often at certain places they are very uneven, one of them being considerably above or below the other. The locomotive upon reaching a defective place like the one mentioned is liable to jump the track, or as the forward wheels reach a place where one of the rails is lower than the other either the locomotive will be left standing upon the three wheels resting upon the track, thus causing great strain upon the entire machine, or the locomotive will oscillate upon the two diagonally opposite wheels which are resting on the rails.

The invention is fully illustrated in the drawings furnished herewith, in which—

Figure 1 is a side elevation of a complete electric locomotive. Fig. 2 is a plan view of a portion of the same and showing the oscillating frame. Fig. 3 is a longitudinal section in line 3 3 of Fig. 2. Fig. 4 is a detail section of the frame taken in line 4 4, Fig. 2. Fig. 5 is a vertical cross-section in line 5 5 of Fig. 3; and Fig. 6 is a section in line 6 6, Fig. 3.

In the drawings, A is a locomotive, its power being derived from an electric motor A', of suitable horse-power and in electrical connection with some suitable source of electrical supply.

*a a* are the tracks upon which the locomotive runs, and they are placed upon the ground or upon ties, but not with great care as to the foundation.

The rear wheels W' are journaled in suitable boxes rigidly secured to the framework of the machine in any desired manner, and the front wheels W W are journaled in an oscillating frame B, to which my invention more particularly pertains.

The shaft *a'* of the motor extends outward

through the frame surrounding the motor, which is preferably provided with a bearing-block in which the shaft is journaled. Near the outer end of the shaft *a'* is keyed or otherwise secured thereon a pinion C, and beyond this the shaft is journaled in a standard D, secured to the base of the locomotive. The pinion C is in mesh with a gear-wheel C', preferably provided with a gudgeon *c*, journaled in suitable bearings upon the standard D. The gear-wheel C' is preferably constructed of a thin web *c*<sup>2</sup>, flanged at its periphery, in which the teeth are cut, and at the center a beveled pinion C<sup>2</sup> is formed integral with the same. The pinion C<sup>2</sup> is in mesh with a beveled gear E, keyed upon the shaft *w* of the wheels W W. Thus the power from the motor is transmitted to the wheels W through the pinion C, gear-wheels C', pinion C<sup>2</sup>, and beveled gear E, which rotates the shaft and propels the locomotive along the track. The rear wheels are also provided with a similar gear, so that both sets of wheels are actuated at the same time and speed.

The shaft *w* is journaled in suitable boxes *b* in the frame B and the main portion of the frame extends at right angles from the boxes in a horizontal line, as seen at B' B', and is formed into a yoke shape embracing the gear-wheel C', the portion B<sup>3</sup> lying along the outer face of said gear-wheel and provided at the proper place with a bearing-box *b'*, in which a gudgeon *d* is journaled, said gudgeon being preferably integral with the standard D and forming one of the supports and pivots for the oscillating frame B. The other portion of the frame extends upward from the boxes, as seen in Fig. 6, and is preferably formed into a yoke B<sup>3</sup>, extending over the bevel-gear E. This portion of the frame is provided with a gudgeon *d'*, extending into the frame A' of the motor, (see Fig. 3,) said gudgeon being concentric with the shaft *c* of the gear-wheel C', and the frame A' is preferably provided with a bearing-block in which the gudgeon may rock. It is evident that if the wheel-carrying frame be pivoted in a line at right angles to the wheel-shaft at its center and lying in a horizontal plane the gear-wheel C' will always be in mesh with the pinion C if either of the wheels are raised or lowered from any defect in the rails. If one of the

wheels W reaches a sudden depression in one of the rails, it can follow said depression by swinging the oscillating frame B upon its pivot  $d d'$  without disturbing the remainder of the locomotive and without permitting any of the gearing from becoming disengaged.

I claim as new and desire to secure by Letters Patent—

1. In a device of the class described, the combination with a frame provided with a suitable motor for its propulsion of a pair of supporting-wheels, a shaft connecting said wheels, an oscillating frame carrying said shaft, said frame being provided with suitable pivots substantially in a line at right angles to the wheel-shaft and passing through the center thereof, a beveled gear located upon the wheel-shaft and in mesh with a beveled pinion journaled in a line concentric with the pivot of the oscillating frame, and a gear-wheel integral with said pinion and in mesh with a pinion secured to the motor-shaft; substantially as described.

2. A wheel-supporting frame for locomotives having suitable journal-boxes for the wheel-shaft, said shaft being provided with the beveled gear, E, in mesh with the pinion, C<sup>2</sup>, the gear-wheel, C', pinion, C, secured to the motor-shaft, said supporting-frame being

provided with pivots in a line parallel to the motor-shaft and passing through the center of the wheel-shaft; substantially as described.

3. A wheel-supporting frame for locomotives and the like, having suitable journal-boxes for the wheel-shaft, a yoke, B<sup>3</sup>, gudgeon,  $d'$ , a yoke, B', B<sup>2</sup>, and journal-box,  $b'$ , said gudgeon,  $d'$ , and box,  $b'$ , being substantially in a line at right angles to the wheel-shaft and passing through the center of the same in substantially a horizontal plane; substantially as described.

4. The combination with a locomotive provided with a suitable motor for its propulsion of the wheels, W, W, shaft,  $w$ , connecting said wheels, the oscillating frame, B, supporting said shaft, gudgeons,  $d, d'$ , carrying said frame, said gudgeons being located in a line at right angles to the wheel-shaft and in a line through the center thereof, the beveled gear, E, pinion, C<sup>2</sup>, gear, C', having a gudgeon,  $c$ , journaled in a line concentric with the pivots,  $d, d'$ , and the pinion, C, secured to the motor-shaft; substantially as described.

HARRY BITNER.

Witnesses:

CHAS. O. SHERVEY,  
M. L. SHEAHAN.